

THIS COPY IS PROVIDED ON A RESTRICTED BASIS AND IS NOT TO BE USED IN ANY WAY DETRIMENTAL TO THE INTERESTS OF PANDUIT CORP.

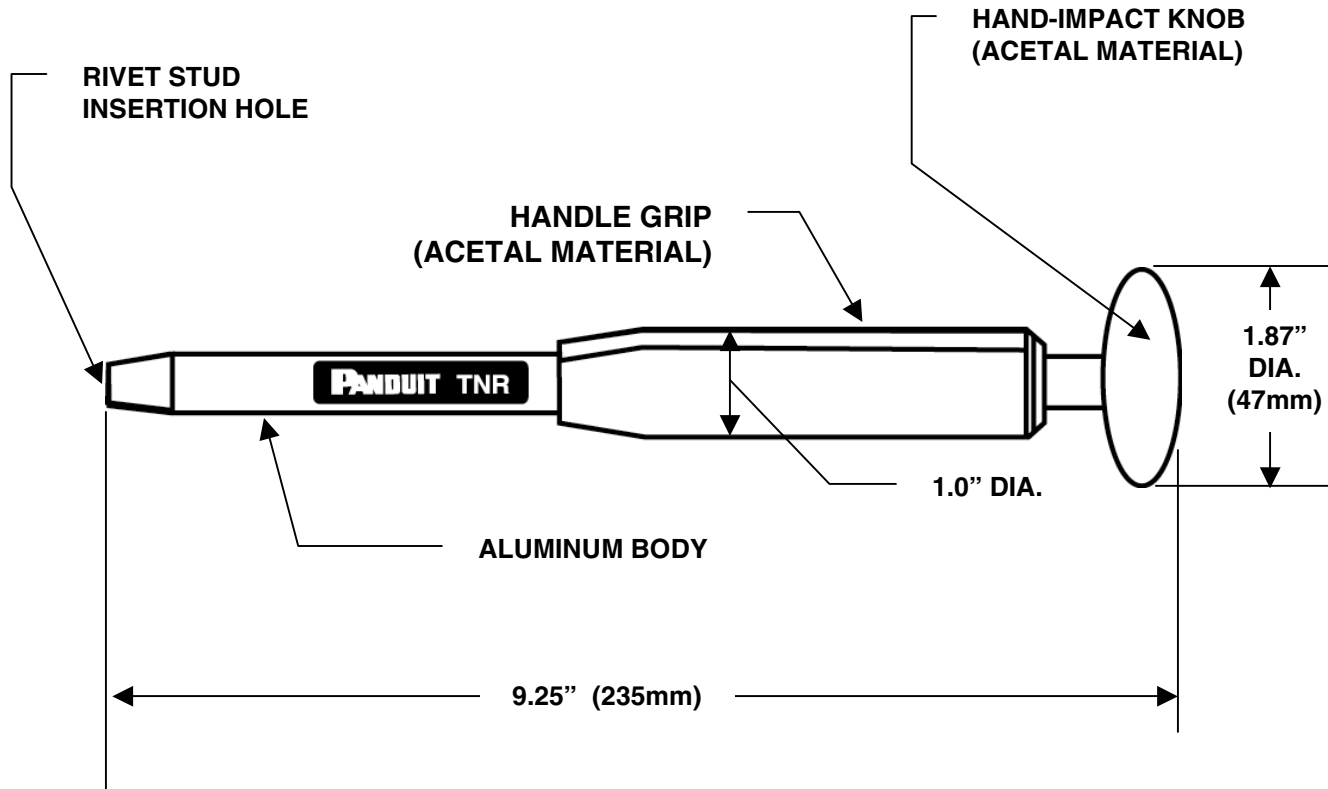

**NOTES:**

For use with *PANDUIT* NR1 Nylon Push Rivets and *PANDUIT* KIMS low profile mounts.

**DIMENSIONS ARE FOR REFERENCE ONLY.**

WEIGHT: 5.1 oz.  
(145.5 gr.)

F:/rvusers/engdocsnew/custdwg/  
TNR-09124A-CD\_01 TNR CD.doc

										CORP. TINLEY PARK, ILLINOIS	
								<b>TNR NYLON PUSH-RIVET TOOL CUSTOMER DRAWING</b>			
								UNLESS OTHERWISE SPECIFIED, DIMENSIONAL TOLERANCES ARE:		UNLESS OTHERWISE SPECIFIED, ALL DIMENSIONS ARE GIVEN IN INCHES, THIRD ANGLE PROJECTION.	
								(.x) ± --- (.xxx) ± ---			
								(.xx) ± --- ANGLES ± ---			
01	3-17-05	BLR	MBR	REDRAWN; ADD WEIGHTS & (DIMS)	4153	--	DLWE	DRAWN BY: BLR	MATL: -----	SCALE NONE	
R	2-20-81	MDE	RJB	RELEASED	09124	R	----	DATE: 3-17-05		DRAWING NO. TNR-09124A-CD	
REV	DATE	BY	CHK'D	DESCRIPTION	ECN	-R	CUST	SUP	CHK'D: MBR		DWG A SIZE